

LOC	DIST	REVISIONS			
F	LTR	DESCRIPTION	DATE	DWN	APVD
P		REVISED PER 0G3B-1208-04	140CT05	KW	SR

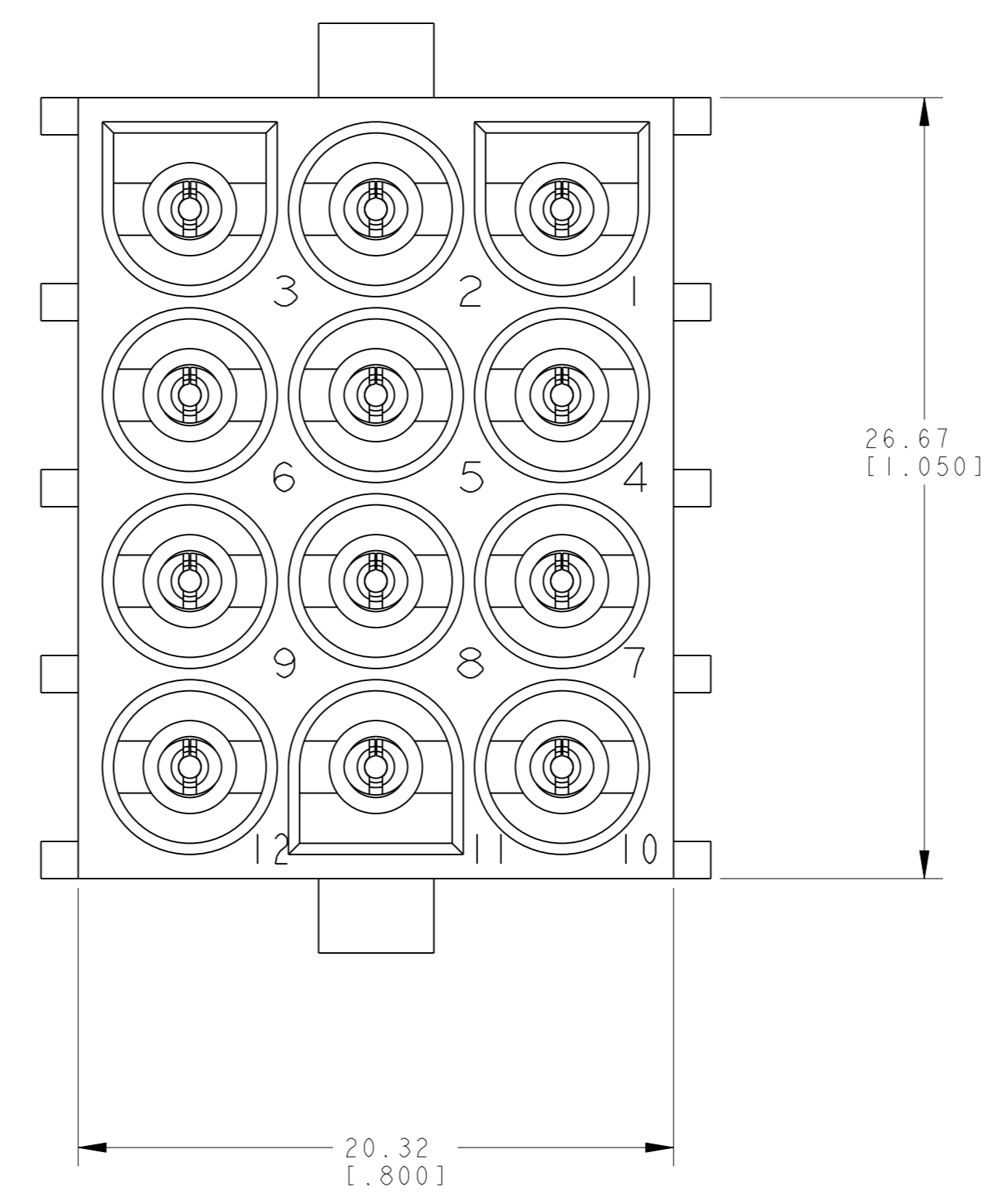

1. PARTS MUST COMPLY WITH AMP SOLDERABILITY SPEC. 109-11-3.
- △ CONTACT IS PLATED OVERALL WITH 0.00127 [0.00050] NICKEL, THEN 0.00076 [0.00030] GOLD OVER CONTACT LENGTH INDICATED AND TIN LEAD ON SOLDER TAIL END.
- △ CIRCUIT IDENTIFICATION ON CHARACTERS ARE ADJACENT TO THE INDICATED CAVITIES, BUT LOCATION AND ORIENTATION MAY DIFFER FROM PRINT.
- △ CONTACT IS PLATED OVERALL WITH 0.00127 [0.00050] NICKEL, THEN 0.00076 [0.00030] GOLD OVER CONTACT LENGTH INDICATED AND MATTE TIN ON SOLDER TAIL END.

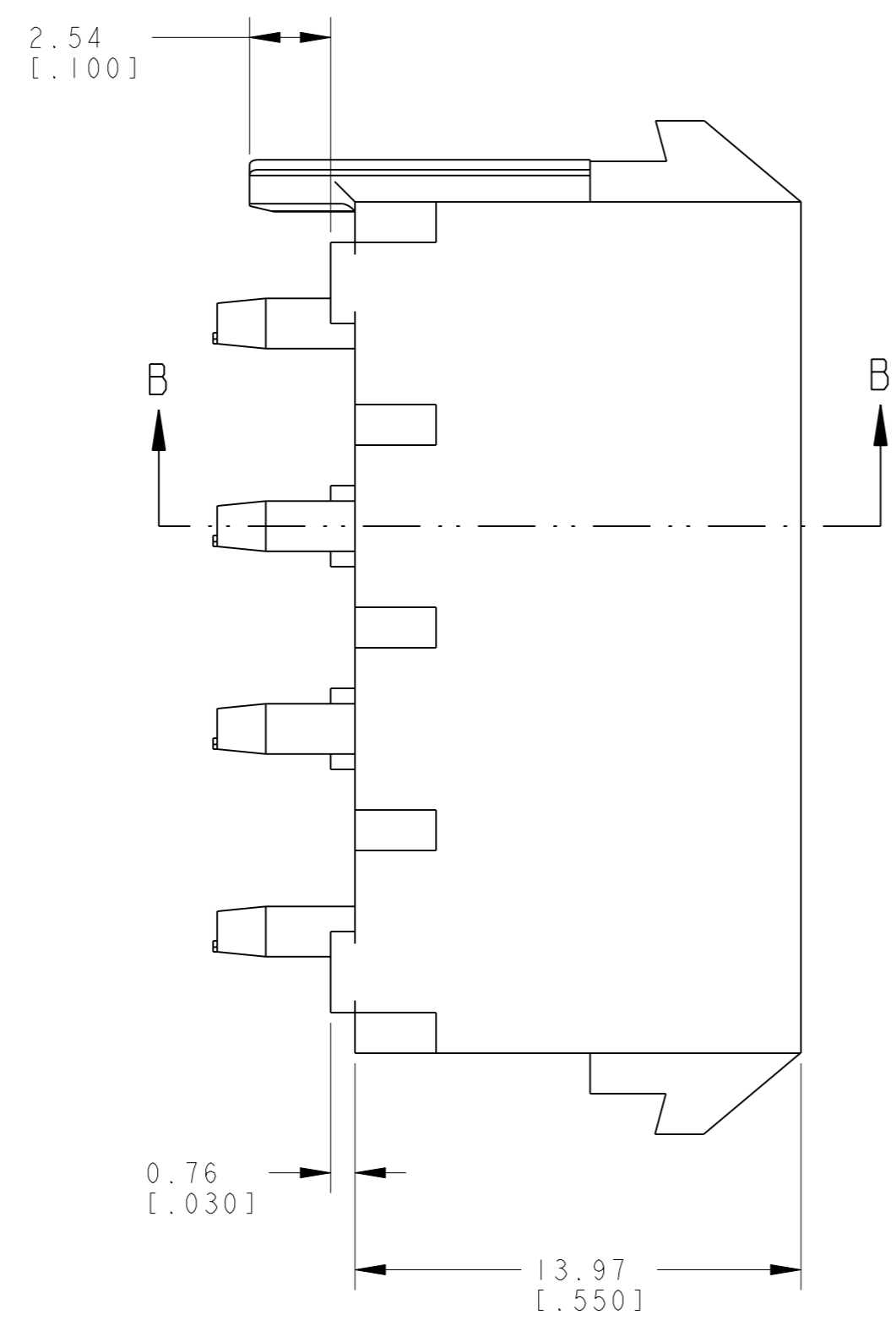
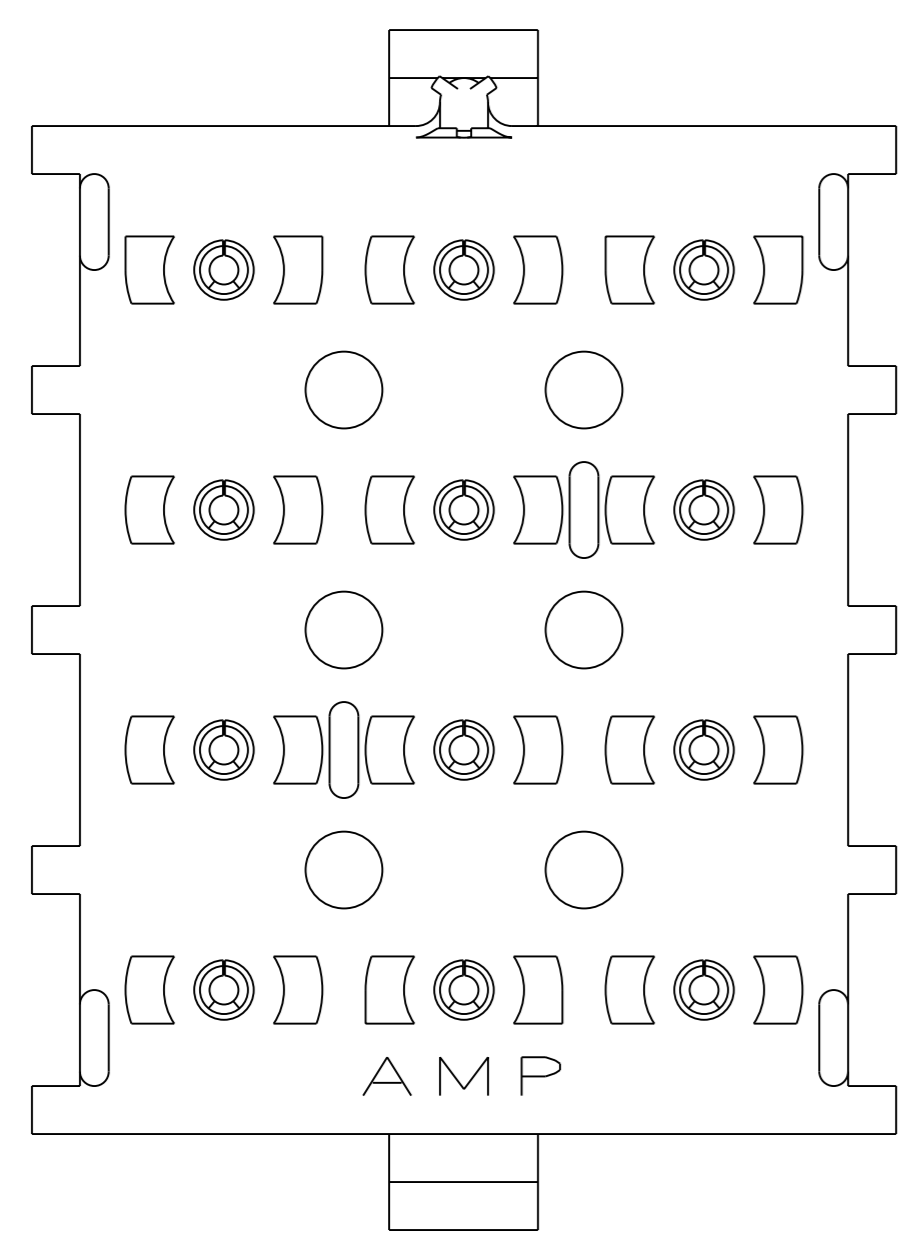
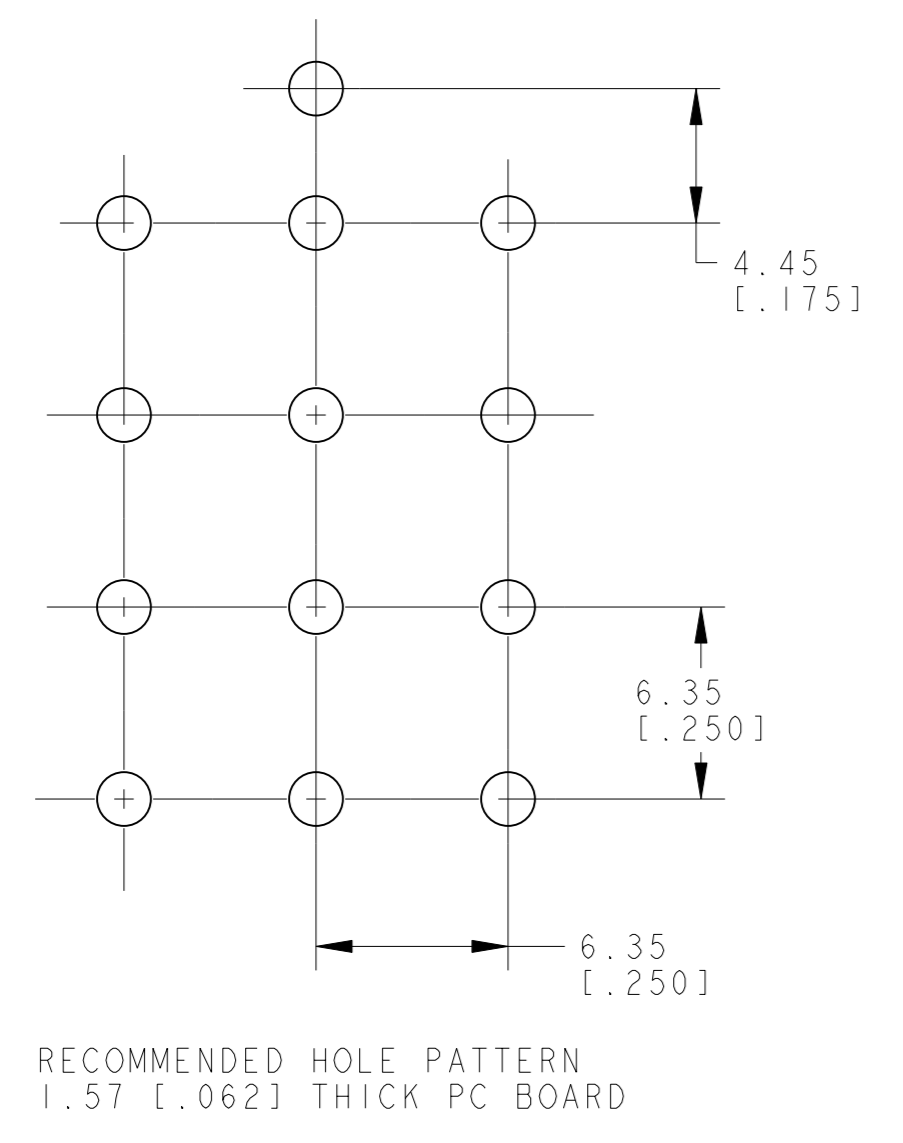
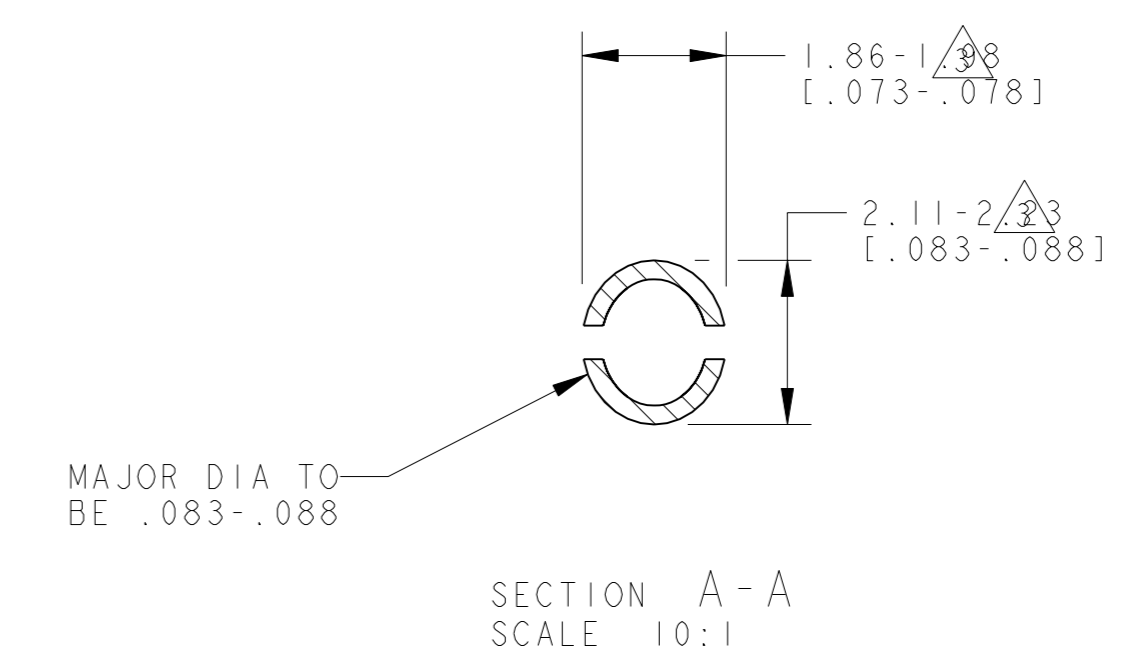
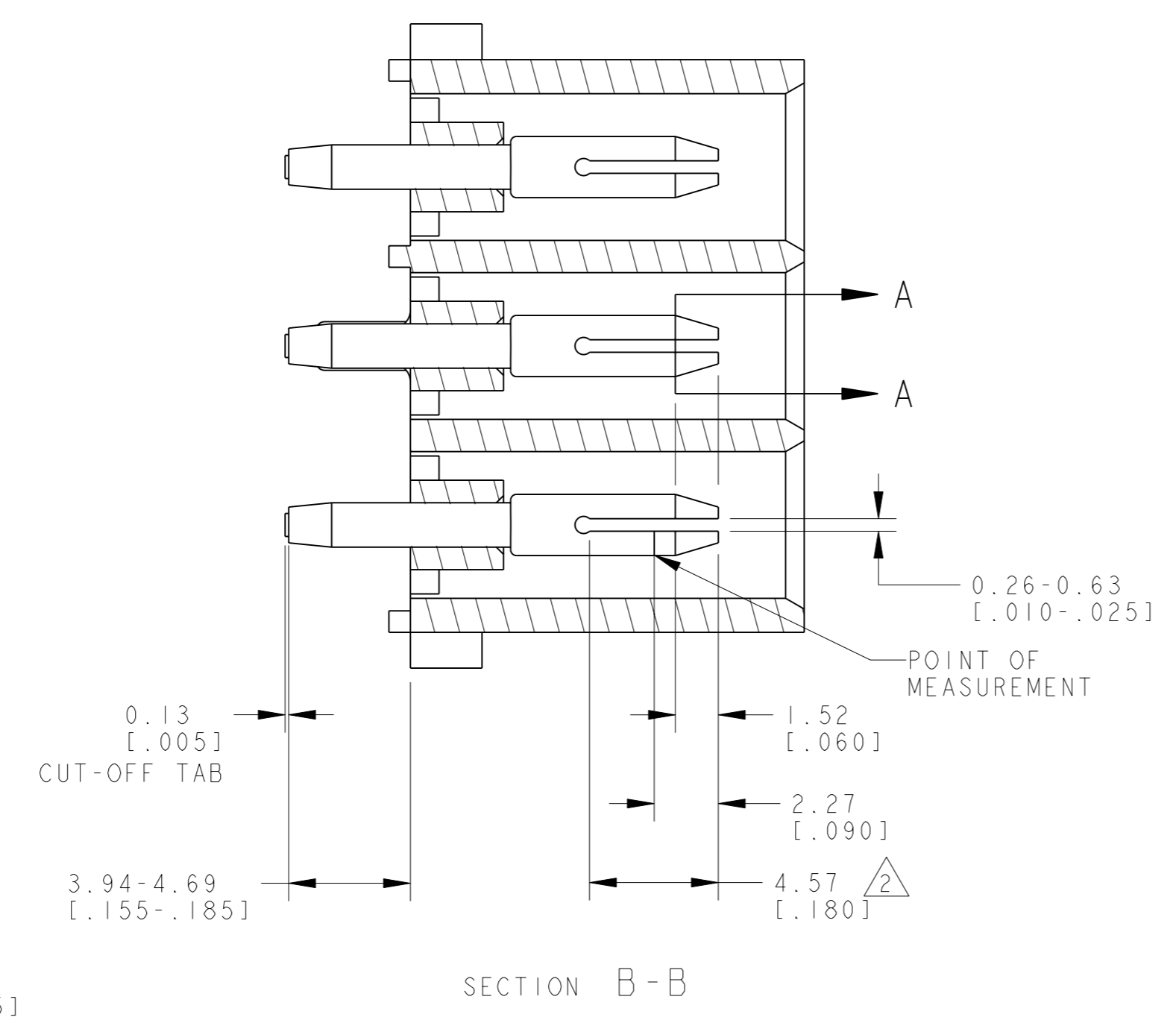

METRIC

MATERIAL	FINISH	MATERIAL	COLOR	PART NO
PH BRZ	PRE-TIN	NYLON, 94V-0	BLACK	1-641974-1
PH BRZ	GOLD △4	NYLON, 94V-0	WHITE	641974-3
PH BRZ	GOLD △2	NYLON, 94V-0	WHITE	641974-2
PH BRZ	PRE-TIN	NYLON, 94V-0	WHITE	641974-1

PIN		HOUSING		PART NO
0 PLC	±			
1 PLC	±			
2 PLC	±			
3 PLC	±.005			
4 PLC	±			
ANGLES	40° 30'			